

## **BIDDING DOCUMENTS**

# **INVITATION FOR BIDS FOR SUPPLY, INSTALLATION, TESTING & COMMISSIONING OF MEDICAL EQUIPMENTS & MACHINERY FOR DIRECTORATE OF AYURVEDA, GOVT. OF RAJASTHAN, AJMER, RAJASTHAN**

## **NATIONAL COMPETITIVE BIDDING**

**BID REFERENCE: IFB No. HSCC/PUR/ISM-RAJ/2009/A Dated 25.03.2009**

### **HSCC (I) LTD.**

(A Govt. of India Enterprises)

Plot No. 6A, Block-E, Sector-1, NOIDA (U.P.) – 201 301.

Tel: 0120-2542436,37,38,40, 2530621

Fax : 0120-2542447, 2533001.

FORWARDING LETTER

To,  
(Prospective Bidder).....  
.....  
.....

Our Ref.: IFB No. HSCC/PUR/ISM-RAJ/2009/A Dated 25.03.2009

Your ref: \_\_\_\_\_

SUBJECT: INVITATION FOR BIDS FOR SUPPLY, INSTALLATION, TESTING & COMMISSIONING OF MEDICAL EQUIPMENTS & MACHINERY FOR DIRECTORATE OF AYURVEDA, GOVT. OF RAJASTHAN, AJMER, RAJASTHAN

Sir

1. Enclosed please find bid document for various items.
2. The date for the Bid receipt and opening will be as per IFB. However, in the event of the day of receipt and opening of tender being declared a holiday, the due date of receipt and opening of tenders will be the following working day at the same time.
3. The bidder is eligible to quote only for the **Item(s)** for which the Bid Security is submitted as per the relevant Clause of Instructions to Bidders.

Kindly acknowledge the receipt of the Bid Document.

Executive Director (Proc. & PG-I)

- Encl: 1. Annexure-A – Important Clauses in brief.  
2. Invitation For Bid (IFB).  
3. Invitation For Bids (IFB) – Details  
4. Section-I - Instructions To Bidders (ITB)  
5. Section-II - General Conditions Of Contract (GCC)  
6. Section-III - Special Conditions Of Contract (SCC)  
7. Formats  
8. Description & Specifications

**Important Clauses in Brief, For Quick Reference only, (BIDDER MUST REFER ALL TERMS & CONDITIONS ETC. ENCLOSED WITH THE BID DOCUMENT IN DETAILS)**

**Instruction to Bidders (ITB)**

- |                                           |   |                                                                                                                                                                                                                                                                                                                                                                                                                                    |
|-------------------------------------------|---|------------------------------------------------------------------------------------------------------------------------------------------------------------------------------------------------------------------------------------------------------------------------------------------------------------------------------------------------------------------------------------------------------------------------------------|
| <b>1. Bid Security Amount</b>             | - | As given in IFB Details.                                                                                                                                                                                                                                                                                                                                                                                                           |
| <b>2. Price Bid</b>                       | - | Please refer Clause 6 of ITB.                                                                                                                                                                                                                                                                                                                                                                                                      |
| <b>3. Statutory Variation</b>             | - | As per Clause 6.4 of ITB. Any variation in the Statutory Levies / Taxes/ Duties/ Cess or any new Levies/ Taxes/ Duties/ Cess on end product shall be payable at actual provided documentary evidence of the prevailing rate quoted at the date of submission of bid and changes at the time of actual supplies (within stipulated delivery period) is furnished.                                                                   |
| <b>4. Optional Items</b>                  | - | As per Clause 6.6 of ITB. Bidder in their own interest should quote separately for any Optional Items of the Technical Specifications. In case the Optional items of the Tender Specifications are not quoted explicitly, then the rate quoted shall be considered for the tendered main item and accordingly price comparison shall be done. No benefit shall be considered for inclusion of Optional Items in the Tendered Item. |
| <b>5. Manufacturer's Authorization</b>    | - | As per Clause 7.2 a of ITB.                                                                                                                                                                                                                                                                                                                                                                                                        |
| <b>6. Bid Document Fee</b>                | - | See Clause 9 [B] of ITB.                                                                                                                                                                                                                                                                                                                                                                                                           |
| <b>7. Bid Validity</b>                    | - | <b>180</b> days as per Clause 10.1 of ITB                                                                                                                                                                                                                                                                                                                                                                                          |
| <b>8. Amount of Performance Security-</b> |   | 10% as per Clause 24 of ITB.                                                                                                                                                                                                                                                                                                                                                                                                       |
| <b>9. Preliminary Examination</b>         | - | As per Clause 17.4 of ITB. <u>The Bid Form, signed by the Bidder which stipulates acceptance of all the terms &amp; conditions of tender document, shall supersede all other terms &amp; conditions given in the tender by the Bidder.</u>                                                                                                                                                                                         |

**General Conditions of Contract (GCC)**

- |                               |   |                                                         |
|-------------------------------|---|---------------------------------------------------------|
| <b>10. Delivery</b>           | - | As per Clause No.9 of GCC.                              |
| <b>11. Insurance</b>          | - | 110% of Order Value as per Clause No.10 of GCC.         |
| <b>12. Payment Terms</b>      | - | 90% & 10%, as per Clause No. 12 of GCC.                 |
| <b>13. Liquidated Damages</b> | - | 0.5% per week max. upto 10% as per Clause No.15 of GCC. |

## **Special conditions of Contract (SCC)**

### **14. Minimum Qualification Criteria**

-

As per Clause 4 A iii of SCC. Bidder shall submit Manufacturer's Authorization as per the Tender format.

### **15. Minimum Qualification Criteria**

-

As per Clause 4 A iv of SCC. Bidders should have in the past 5 years, satisfactory executed for the **Item(s)** offered, at least one single order of like nature of item and quantity not less than 80% of quantity of **Item (s)** offered by bidder. The Bidders shall furnish "Satisfactory End User Certificate" indicating contract details i.e. name of person, phone/fax /mobile nos. etc.

### **16. Other eligibility requirements**

-

As per Clause 4 B ii) of SCC. The Bidder should submit audited balance sheet and Profit & Loss Account along with audited report for the last 3 years to enable the purchaser to assess the financial capability of the bidder or positive net worth of the bidder.

### **17. Bid Form**

-

To be submitted as per Clause 6 of SCC in the given format.

### **18. Components & Quantities**

-

All components/ quantities of an Item (s) must be quoted as per Clause 9 of SCC.

### **19. Turnkey activities**

-

The offer should be on turn-key basis including all costs incidental to the same as per Clause 12 & 15 of SCC.

**GOVT. OF RAJASTHAN  
DIRECTORATE OF AYURVEDA  
AJMER, RAJASTHAN**

**Through**

**HSCC (I) LTD.**

(A Govt. of India Enterprises)

Plot No. 6(A), Block-E, Sector-1, NOIDA (U.P.) – 201 301.

Tel: 0120-2542436,37,38,40, 0120-2530621

Fax : 0120-2542447, 2533001.

**National Competitive Bidding**

**INVITATION FOR BIDS (IFB)**

IFB Reference: **HSCC/PUR/ISM-RAJ/2009/A**

**Dated: 25.03.2009**

**Directorate of Ayurveda, Govt. of Rajasthan, Ajmer, Rajasthan through HSCC (India) Limited invites sealed bids from Manufacturers/ Authorized Indian Agents only in Single stage two bid system for Procurement, Supply, Installation, Testing & Commissioning of Medical Equipment detailed below to be delivered at various consignee location in the State of Rajasthan:**

Sr. No.	Item Description	Quantity in Nos.	Bid Security (in Rs.)
<b>GROUP-1 (Medical Equipments)</b>			
1.	Dressing Drums	156	4100.00
2.	Instrument Sterilizers (Table Model)	50	1250.00
3.	Formalin Sterilizers	52	650.00
4.	Bowel Stand SS	156	2500.00
5.	Revolving Stool	96	1250.00
6.	Dissecting Scissor	52	500.00
7.	Dissecting Scissor	52	500.00
8.	Needle holder (Mathieu's pattern)	52	1800.00
9.	Sponge Holding Forceps	156	650.00
10.	Halsted's Mosquito Forceps	104	650.00
11.	Halsted's Mosquito Forceps	104	650.00
12.	Spencer well's Haemostatic Forceps	156	1000.00
13.	Spencer well's Haemostatic Forceps	156	1000.00
14.	B. P. Instrument	100	1500.00
15.	Stethoscope	78	500.00
16.	B. P. Handel	46	500.00
17.	Scissor	125	900.00
18.	Scissor	125	900.00
19.	Artery Forceps	206	1500.00
20.	Artery Forceps	156	1100.00
21.	E N T Set Complete (Otoscope)	51	10500.00
22.	Tongue Depressor	50	500.00
23.	Foreign Body Remover Forceps	75	600.00

24.	Hot Water Rubber Bag	48	500.00
25.	Torch	100	500.00
26.	Gas Stove (Two Burner )	52	1600.00
27.	Pestle Mortar	78	600.00
28.	Urinal Pot	48	1000.00
29.	Catheter	296	500.00
30.	Wheel Chair	74	7500.00
31.	Bed Screen with Curtain	51	750.00
32.	Stretcher on Trolley	72	4000.00
33.	Patient Examination Table	78	5000.00
34.	X-ray view Box	78	500.00
35.	Avagahan Koshta (Steam Room)	52	5500.00
36.	Pressure Cooker	52	1600.00
37.	Bucket	80	500.00
38.	Measuring Glasses	72	700.00
39.	I.V Stand	78	800.00
40.	Diathermy machine	26	13000.00
41.	Medicine Distribution Counter	100	10000.00
42.	Polythene pouch Sealer Machine	26	105000.00
43.	Mobile O.T. Light	26	13000.00
44.	Mechanical weighing machine	25	5000.00
45.	Glucometer	48	5000.00
46.	Instrument Tray	74	1500.00
47.	IR Lamp	78	1000.00
48.	Sarvang Vashap Sanvedan Yantra with Trolley Laying Type (Full Body Steam Bath as per specifications)	52	10500.00
49.	Vasti Yantra	52	1000.00
50.	Shiro Vasati Cap	52	500.00
51.	Panchkarma Accessories	52	1000.00
52.	Cervical Cum Lumbar Traction level	26	24000.00
53.	Patient Waiting Chair (Three Seat)	80	4000.00
54.	Room Heater Covered	54	3500.00
55.	Table Lamp	52	500.00
56.	Refrigerator	52	16000.00
57.	Mixer Grinder with all attachments	52	47000.00
58.	Instrument Cabinet	26	3600.00
59.	Oxygen Regulator	52	2500.00
60.	Gas Stove (One Burner)	52	1500.00
61.	Babcock's Tissue Forceps	26	500.00
62.	Kettle Steel	26	1000.00
63.	Pindichal Yantra	26	2000.00
64.	Measuring Jug	52	500.00
65.	Measuring Bucket	52	1000.00
66.	Arshvashp Sanvedan Yantra	52	1000.00
67.	Weighing Machine Baby	23	1200.00
68.	Doctor's Head Light	23	1200.00
69.	Digital Thermometer	112	3000.00
70.	Spatula	46	500.00
71.	Dressing Forceps	46	500.00
72.	B.P. Instrument with Stand	23	500.00
73.	Ice Bag	46	500.00
74.	Auto Clave vertical Portable	23	42000.00
75.	B.P. Instrument	100	3000.00
76.	Cheatle Forceps	52	1000.00
77.	Drinking Water Cooler	26	5200.00

<b>GROUP-2 (Machinery)</b>			
1.	Pouch Packing Machine with Auger Filler	4	25000.00
2.	Micro- Pulverize	1	10000.00
3.	Edge- Runner	2	6000.00
4.	Automatic Filling Plugging and Over Capping Machine for Eye & Ear Drop Bottle	1	36000.00
5.	Trip Trolley	8	20000.00

- i) Bid evaluation will be done on the basis of total "All inclusive lump sum price" to be offered for each **Item**. Any part / incomplete offer in a particular **Item** shall be rejected.
- ii) Sealed bids to be submitted in single stage two bid system, i.e., Techno Commercial Bid (un-priced bid) and Price bid, for any or all of the above mentioned items, including Bid Security.
- iii) The bidders shall be required to furnish a Bid Security for each **Item** offered along with the Bid for an amount specified herein above in the form of Demand Draft drawn in favour of HSCC (I) Limited from any Nationalised bank payable at NOIDA or New Delhi. The successful bidder will be required to furnish Contract Performance Security for 10% of contract value in the form of a Demand Draft drawn in favour of HSCC from any Nationalised bank payable at NOIDA or New Delhi within 10 days of issue of notification of award of contract. All relevant terms and conditions of tender and other details are available in bid documents.
- iv) Bidders may quote for any one or more items but Bid Security should be given separately for each **Item** as indicated above.
- v) Bids shall be evaluated separately for each **Item**.
- vi) In case of goods of import origin, a foreign manufacturer can quote through their authorized Indian agent.
- vii) Log on to <http://www.hsccltd.com/> for copy of Invitation for Bids and downloading of Bidding Documents.

**BIDDING DOCUMENTS:** Bidding Documents can be downloaded from <http://www.hsccltd.com/> free of cost upto last date of submission of bid i.e. 28.05.2009 upto 14.00 Hrs. The cost of the bidding documents is Rs.3500/-. Please refer to the Clause 9[B] of ITB of Bidding Documents for details regarding payment of the Bidding Documents fee.

The last date for submission of bids has been kept on **28.05.2009 upto 14.00 hrs.**

Bidders request for waiver, alteration etc. in respect of Bidding Documents fee, Bid Security, contract Performance Security etc will not be accepted and hence no formal reply will be given for such request.

Bids should reach the office of HSCC (India) Ltd., on or before the last date mentioned above i.e. **28.05.2009 upto 14.00 Hrs.**

Only the Techno-Commercial bid shall be opened in the presence of participating Bidders on the respective last date i.e. **28.05.2009 from 14.50 hrs.** The techno commercial bid shall not be opened of those bidders who fail to submit Bidding Documents Fee and Bid Security as per provisions of the Bidding documents. Based on the outcome of the Techno-Commercial evaluation, the Price bid of those bidders, who are found technically and commercially eligible, will only to be opened at a later date to be intimated to successful Bidders.

HSCC takes no responsibility for delay, loss or non-receipt/ downloading of Bidding Documents either way.



All prospective bidders may attend the pre-bid meeting schedule to be held on **12.05.2009 at 2.30 hrs.** at HSCC, NOIDA office. The representatives of the bidders who choose to attend the meeting must accompany with necessary authorization letter from bidder.

HSCC reserves the right to accept or reject any or all of the Bids in full or in part including the lowest bid without assigning any reasons thereof or incurring any liability thereby.

**Executive Director (Proc. & P.G.-I)**  
**HSCC (I) LTD.**

(A Govt. of India Enterprises)

Plot No. – 6 A, Block-E, Sector-1, NOIDA (U.P.) – 201 301.

Tel: 0120-2542436, 37, 38, 40 , 2530621

Fax : 0120-2542447, 2533001

## **SECTION-I**

### **INSTRUCTIONS TO BIDDERS (ITB)**

This bid document should be read in conjunction with the Press Tender Notice/IFB, Ref. No. **HSCC/PUR/ISM-RAJ/2009/A** Dated 25.03.2009, a copy of which is enclosed in this document and all clauses to be read in conjunction with any other instruction given else, where, in this document, on the same subject matter of the clause.

#### **1. THE BIDDING DOCUMENTS:**

##### **CONTENT OF BIDDING DOCUMENTS:**

- 1.1 The Goods required, bidding procedures and tender & contract terms are prescribed in this Bidding Document and includes (i) IFB, (ii) IFB (Details), (iii) Section I (ITB), (iv) Section II (GCC), (v) Section III (SCC), (vi) Annexure-1 Schedule of Requirement (Description & Specifications), (vii) Formats for Consignee receipt, Bid form, Performance Statement Proforma and Manufacturer's Self Authorisation form & Manufacturer's Authorization form (for Equipments of Imported origin).
- 1.2 The Bidders are expected to examine all instructions, terms, specifications etc. in the Bidding Documents. Failure to furnish information required by Bidding Documents or submission of a Bid not in compliance to the Bidding Documents will be at the Bidder's risk and may result in rejection of its Bid.

##### **1.3 COST OF BIDDING:**

The Bidder shall bear all costs associated with the preparation and submission of its Bid, and Directorate of Ayurveda, Govt. of Rajasthan, Ajmer acting through their Consultants, M/s HSCC (I) Ltd., hereinafter referred to, as "The Purchaser" will in no case be responsible or liable for those costs, regardless of the conduct or outcome of the bidding process.

#### **2. CLARIFICATION IN BIDDING DOCUMENTS:**

A prospective Bidder requiring any legitimate clarification of the Bidding Documents may notify the Purchaser in writing at the Consultant's mailing address indicated in the Invitation for Bids. The Purchaser will respond in writing to any request for clarification of the Bidding Documents that it receives not later than 15 days prior to the deadline for the submission of bids prescribed by the Purchaser. Written copies of the Purchaser's response (including explanation of the query but without identifying the source of inquiry) will be sent to all prospective bidders who have received the bidding documents and shall be displayed on the HSCC's website <http://www.hsccltd.co.in> by the date mentioned in the Forwarding Letter.

3. **AMENDMENT OF BIDDING DOCUMENTS :**

- 3.1 At any time prior to the deadline for submission of Bids, the Purchaser may, for any reason, whether at its own initiative or in response to a clarification requested by a prospective Bidder modify the Bidding Documents by amendment.
- 3.2 The amendment will be notified in writing or by Fax or cable to all prospective Bidders who have received the Bidding Documents and will be binding on them.
- 3.3 In order to afford prospective Bidders reasonable time to take the amendment into account in preparing their Bids, the purchaser may, at its discretion, extend the deadline for the submission of Bids.

4. **LANGUAGE OF BID :**

- 4.1 The Bid prepared by the Bidder and all correspondence and documents relating to the Bid exchanged by the Bidder and the purchaser, shall be written in the English language, provided that any printed literature furnished by the Bidder may be written in another language so long as it is accompanied by an English translation of its pertinent passages in which case, for purposes of interpretation of the Bid, the English translation shall govern.

5. **DOCUMENTS COMPRISING THE BID :**

The two-part Bid, that is, Techno-commercial bid and Price bid prepared by the Bidder shall comprise the following:

- a) Techno-commercial Bid (un-priced bid): This should interalia include the following:
- i) Bid Security furnished in accordance with Clause 9.
  - ii) Detailed technical specifications of **Items** quoted and if applicable, along with Catalogue / Literature fabrication drawings, make and model of the equipment offered with prices blanked (without indicating the prices).
  - iii) Statement of Deviations parameterwise from Tendered Commercial conditions, if any.
  - iv) Statement of Deviations parameterwise from tendered Technical specifications if any;
  - v) Authority Letter from manufacturer in case Bid is submitted by Agents;
  - vi) Bidders to indicate Name and Address of their Bankers; and
  - vii) Audited balance sheet and Profit & Loss Account along with audited report for the last 3 years.

- viii) Documentary evidence established in accordance with Clause 7 that the Bidder is qualified to perform the contract if its Bid is accepted.
  - ix) Documentary evidence established in accordance with Clause 8 that the Goods and Ancillary to be supplied by the Bidder are eligible Goods and Services and conform to the Bidding Documents;
  - x) Proof of payment of Bid Document Fee as per clause 9[B].
- b) Price Bid: The information given at Sr. No. 5 (a) (ii) above should be reproduced but with prices indicated. The prices shall be all inclusive lumpsum prices as per description given at Clause No. 6.

## 6. **BID PRICE :**

- 6.1 (a) The Price bid for the **Item (s)** to commensurate with scope of supply indicated against the **Item (s)** and should indicate all inclusive lump sum price offered for each equipment/store including cost of the stores, freight, insurance, transit insurance, packing forwarding, Sales Tax, Excise duty, Basic Custom Duty upon production of CDEC, Inspection/Inspection certificate charges (ISO certified inspection agencies), road permit costs etc. and including charges whatsoever applicable, for equipment installation and commissioning with all the men and material required for the same and including charges, for one years comprehensive warranty service with spares with downtime not more than 48 hours, regular maintenance plans during warranty. The all inclusive lump sum price should be on **F.O.R. Site (i.e. delivered at consignee destination)**, for the above and inclusive of all charges stated herein above. **The all inclusive lump sum price needs to be accompanied by a statement indicating a clear “break up” of all inclusive lump sum price of its various components constituting it along with values/amount indicating against each of such components adding to arrive at all inclusive lump sum price.** The prices are to be kept valid for acceptance up to 180 days from the date of the opening of bids. No other charges in addition will be payable on any account over and above the lump sum price quoted. The prices should be given both in figures and words. Offers with price variation clause will not be accepted, the rates quoted in ambiguous terms such as “freight on actual basis” or “taxes as applicable extra” or “packing forwarding extra” will render the bid liable for rejection. Sales Tax will be local Sales Tax, VAT or applicable CST (for inter state sales), whichever applicable will be incorporated in the above all inclusive lump sum price. Custom duty exemption certificate and octroi exemption certificate will be issued by consignee and price to be quoted accordingly.

Bidders in their own interest shall ascertain the eligibility of whatsoever concessions and exemptions eligible and applicable and shall advice the purchaser and quote accordingly. Bidders shall indicate the actual amount of octroi, excise duty, normal sales tax, basic custom duty, etc. which becomes otherwise payable in the extreme event of consignee not in a position to release certificates like CDEC, Octroi Exemption Certificate etc.

6.1(b) **Offer for Import Origin Goods**

Offers for Import origin goods shall clearly indicate firm, "All inclusive lump sum price" calculated in equivalent Indian Rupees and giving break up of as FOB (Free on Board), Marine Insurance, CIF (Cost Insurance Freight), Custom clearance charges, examination, stamp duty, local transportation and Insurance etc. and all other charges for services to be rendered as explained under offer for Indigenous goods. The all inclusive lumpsum price shall take care of impact of foreign exchange rate fluctuations etc. and accordingly arrive at the all inclusive lump sum price in equivalent Indian Rupees and this shall be the ceiling amount payable against the order irrespective of whatsoever higher fluctuations in exchange rate applicable at the time of L/c negotiation. All ordered conditions shall be adhered with the ceiling amount. Customs handling & clearance will be the responsibility of Indian agent at his cost. CDEC/ NMIC will be provided by Directorate of Ayurveda, Govt. of Rajasthan, Ajmer.

6.1 (c) The payments to both indigenous supplies as well as import supply shall have a ceiling amount, which would be the All Inclusive lump sum price.

6.2 The purchaser will evaluate Bids based on all inclusive lump sum prices quoted for each **Item**.

6.3 The All inclusive Lump sum price will include cost of one year comprehensive warranty with spares.

6.4 **Any variation in the Statutory Levies / Taxes/ Duties/ Cess or any new Levies/ Taxes/ Duties/ Cess on end product shall be payable at actual provided documentary evidence of the prevailing rate quoted at the date of submission of bid and changes at the time of actual supplies (within stipulated delivery period) is furnished.**

6.5 The bidder shall bear all taxes / duties/ incidental charges for the parts replaced or supplied during the Warranty period.

6.6 **Bidder in their own interest should quote separately for any Optional Items of the Technical Specifications. In case the Optional items of the Tender Specifications are not quoted explicitly, then the rate quoted shall be considered for the tendered main item and accordingly price comparison shall be done. No benefit shall be considered for inclusion of Optional Items in the Tendered Item.**

7. **DOCUMENTS ESTABLISHING BIDDER'S ELIGIBILITY AND QUALIFICATION:**

7.1 The Bidder shall, furnish, as part of its Bid, documents establishing the Bidder's qualifications to perform the contract if its Bid is accepted.

7.2 The documentary evidence of the Bidder's qualifications to perform the contract if its Bid is accepted, shall establish to the Purchaser's satisfaction:

- a) that, in the case of a Bidder offering to supply Goods of import origin under the contract which the Bidder did not manufacture or otherwise produce, the Bidder has been duly authorised by the Goods manufacturer or producer to supply the Goods. In this regard, the Bidder should submit an Authority Letter from their manufacturers.

In case of a Item comprising group of items, then Bidder may give Manufacturer's authorisation for main equipment from the Principals and other equipment from other manufacturer's of his choice (indigenous/imported) for which Bidder shall submit Manufacturer's Authorization as per the Tender format.

- b) The Purchaser will determine to his satisfaction whether the Bidder selected is qualified as per requirement of minimum qualifying criteria to satisfactorily perform the contract;
- c) The determination will take into account the Bidder's financial, technical and production capabilities. It will be based upon an examination of the documentary evidence of the Bidder's qualifications submitted by the Bidder as well as such other information as the Purchaser deems necessary and appropriate;

Notwithstanding anything stated above, the Purchaser reserves the right to assess the capability and capacity of the Bidder to perform the contract, should the circumstances warrant such as assessment in the overall interest of the Purchaser.

8. **DOCUMENT ESTABLISHING GOODS' ELIGIBILITY AND CONFORMITY TO BIDDING DOCUMENTS:**

- 8.1 The Bidder shall furnish, as part of its Bid, documents establishing the eligibility and conformity to the Bidding Documents of all Goods and services that the Bidder proposes to supply under the contract.
- 8.2 The documentary conforming evidence of the Goods' and Services' conforming to the Bidding Documents may be in the form of literature, drawings and data, and shall comprise of:
- a) a detailed description of the Goods essential technical and performance characteristics;
- b) **a clause-by-clause commentary on the Purchaser's technical specifications demonstrating the Goods and Services substantial responsiveness to those specifications or a statement of deviations and exceptions to the provisions of the Technical Specifications.**
- 8.3 For purpose of the commentary to be furnished pursuant to clause 8.2(b) above, the Bidder shall note that standards for workmanship, material and equipment, and reference to brand

names or equipment, and reference to brand names or catalogue numbers designated by the Purchaser in its Technical Specification are intended to be descriptive only and not restrictive. The Bidder may substitute alternative standards, brand names and/or catalogue numbers in its Bid, provided that it demonstrates to the Purchaser's satisfaction that the substitutions are substantially equivalent or superior to those desired & designated in the Technical Specification.

## 9. **BID SECURITY**

- 9.1 **The Bidder shall furnish, as part of its Bid, Security as indicated in Invitation for Bids (IFB)/ Press Tender Notice, in a separate single sealed envelope and shall be marked as given under clause 12.0 of this ITB.**
- 9.2 The Bid Security is required to protect the Purchaser against the risk of Bidder's conduct, which would warrant the security's forfeiture, pursuant to para 9.7.
- 9.3 **The Bid Security shall be in the form of a Demand Draft drawn in favour of M/s HSCC (India) Limited, payable at Noida or New Delhi from a Nationalised/ Scheduled bank.**
- 9.4 Any Bid not secured in accordance with paras 9.1 to 9.3 will be rejected by the purchaser as non-responsive pursuant to Clause 17 and following which both the techno-commercial & price bid will be treated as invalid.
- 9.5 Unsuccessful Bidder's Bid Security will be discharged/returned as promptly as possible but not later than 30 days after the expiration of the period of Bid Validity prescribed by, clause 10.
- 9.6 The successful Bidder's Bid Security will be discharged upon the Bidders furnishing the performance Security, pursuant to Clause 23 & 24.
- 9.7 The Bid Security may be forfeited:
  - a) if a Bidder withdraws or modifies its Bid during the period of Bid validity; or
  - b) in the case of a successful Bidder, if the Bidder fails :
    - i) to sign the contract in accordance with Clause 23 ;
    - ii) to furnish Performance Security in accordance with Clause 24.
    - iii) if the bidder does not accept an error correction pursuant to clause 17.2
- 9.8 No interest will be payable by the Purchaser on the Bid Security.

9 [B] **Bid Document Fee:**

**Bid Document Fee is Rs.3500/-. Bid Document Fee paid is non-refundable and the Bid Documents are non-transferable.**

Bidders will deposit the Bid Document Fee at HSCC office at Noida. Fee can be deposited either in cash or through crossed account payee Demand Draft drawn in favour of HSCC (I) Ltd. drawn on any nationalized/Scheduled bank payable at NOIDA/New Delhi, before date & time of submission of bid. The Bids will not be accepted without proof of payment of the Bid Document Fee.

A bidder can quote for one or more Items by paying just once for the bid document fee of Rs.3500/-.

**The bidder can contact Consultant, for any clarification in the matter.**

10. **PERIOD OF VALIDITY OF BIDS:**

10.1 **Bids shall remain valid for 180 days** after the date of Bid opening prescribed by the Purchaser, pursuant to Clause 13. A Bid expressed to be valid for a shorter period may be rejected by the Purchaser as non-responsive.

10.2 In exceptional circumstances, the Purchaser may solicit the Bidder's consent to an extension of the period of validity. The request and the responses thereto shall be made in writing or by cable. The Bid Security provided under Clause 9 shall also be extended suitably. A Bidder may refuse the request without forfeiting its Bid Security.

A bidder granting the request will not be required nor permitted to modify its bid.

11. **PREPARATION AND SIGNING OF BID:**

11.1 The Bidder shall prepare single stage Two part bids, i.e. Techno Commercial Bid (un-priced) in duplicate and Price Bid in duplicate clearly marked as 'original' and 'copy' in addition shall enclose Bid Security in a single sealed third envelope.

11.2 The Bid shall be typed or written in indelible ink and shall be signed by the Bidder or persons duly authorised to bind the Bidder to the contract. The later authorisation shall be indicated by written power-of-attorney accompanying the Bid. All pages of the Bid, except for un-amended printed literature, shall be initialled and stamped by the person or persons signing the Bid.

11.3 The Bid shall contain no inter-lineations, erasures or overwriting except as necessary to correct errors made by the Bidder, in which case such corrections shall be initialled by the person or persons signing the Bid.

12. **SUBMISSION OF BIDS:**

12.1 **SEALING AND MARKING OF BIDS:**

The Bidders shall seal the Bid in an inner and an outer envelope duly marking the envelopes, separately as “Techno-commercial Bid (un-priced)”, “Price Bid” and “Bid Security & Copy of Proof of payment of Bidding Document Fee” in a third envelope and all these three envelopes enclosed in another sealed envelope duly marked.

12.2 The inner and outer envelopes shall be:

- (a) Addressed to Executive Director (Proc. & PG-I), HSCC (I) Ltd., Plot No. E-6 (A), Sector - 1, NOIDA – 201 301 as indicated in IFB:
- (b) bear (the Project name), the Press Tender Notice reference, and the words "DO NOT OPEN BEFORE....."

12.3 The inner envelope shall indicate the name and address of the Bidder.

12.4 If the outer envelopes is not sealed and marked as required in Para 12.2, the Purchaser will assume no responsibility for the Bid's misplacement or premature opening.

13. **DEADLINE FOR SUBMISSION OF BIDS i.e. TECHNOCOMMERCIAL BID (UNPRICED) AND PRICE BID INCLUDING BID SECURITY**

13.1 As indicated in the Press Tender Notice/IFB.

13.2 Bids sent by post should be preferably sent by Registered Post with Acknowledgement Due. If any Bidder desires to deliver the Bid by hand, such Bid should be put in the Tender (Bid) Box by the specified date and time. Tender (Bid) Box is available in the HSCC office at the mentioned address.

Bids must be received by the Purchaser at the address specified on the date and time as mentioned in the “Press tender Notice”. Bids will be opened in the presence of Bidders' representatives who choose to attend. In the event of due date being declared a closed holiday then the due date for submission of Bids and the opening of Bids will be the following working day at the appointed time.

13.3 The Purchaser may at its discretion extend this deadline for the submission of Bids by amending the Bidding Documents in accordance with clause 3, in which case all rights and obligations of the Purchaser and Bidders previously subject to the deadline will thereafter be subject to the deadline as extended.

14. **LATE BIDS & MODIFICATIONS/WITHDRAWAL OF BIDS**

14.1 Any Bid received by the Purchaser after the deadline for submission of Bids prescribed by the Purchaser, pursuant to clause 13 will be rejected.

- 14.2 The Bidder may modify or withdraw its bid after the bid's submission provided that written notice of the modification or withdrawal is received by the Purchaser prior to the deadline prescribed for submission of bids.
- 14.3 The Bidder's modification or withdrawal notice shall be prepared, sealed, marked and dispatched in accordance with the provisions of ITB Clause 12. A withdrawal (but not modification) notice may also be sent by cable or fax but followed by a signed confirmation copy, post marked not later than the deadline for submission of bids.
- 14.4 No bid may be modified subsequent to the deadline for submission of bids.
- 14.5 No bid may be withdrawn or modified in the interval between the deadline for submission of bids and the expiry of the period of bid validity withdrawal or modification of a bid during this interval may result in the Bidder's forfeiture of its security, pursuant to ITB Clause 9.7.
15. **OPENING OF BIDS BY PURCHASER:**
- 15.1 The Purchaser will open the Techno-commercial bid only, in the presence of Bidder's representatives who choose to attend, in the HSCC office, on the due date and time as mentioned in the IFB. The Bidder's representatives who are present shall, sign a register evidencing their attendance. **The Bidders' representatives shall furnish letter of Authority from their principals to attend the Bid opening.**
- 15.2 The Bidders' names, the presence or absence of the requisite Bid Security and such other details in brief as the Purchaser, at its discretion, may consider appropriate will be announced at the opening.
- 15.3 Price Bid of bidders whose offers (Techno-commercial bid) are found technically and commercially suitable and comply with the Bid Documents will only be opened on a date to be intimated later to these bidders.
- 15.4 Bids that are not opened and read out at bid opening shall not be considered further for evaluation irrespective of the circumstances. Withdrawn bids shall be returned unopened to the bidders.
- 15.5 **Non-submission of Bid Security & Bid document fee by any bidder will render the bidder invalid and such bidder's bid will not be opened.**
16. **CLARIFICATION OF BIDS:**
- 16.1 To assist in the examination, evaluation and comparison of Bids the Purchaser may, at its discretion, ask the Bidder for a clarification of its Bid.

- 16.2 Clarifications sought & reply received to be all in writing, no change in price or substance of Bid permitted.

**17. PRELIMINARY EXAMINATION:**

- 17.1 The Purchaser will examine the Bids to determine whether they are complete, whether any computational errors have been made, whether required sureties have been furnished, whether the documents have been properly signed, stamped and whether the Bids are generally in order.
- 17.2 Arithmetical errors will be rectified on the following basis: - If there is a discrepancy between the unit price and the total price that is obtained by multiplying the unit price and quantity, the unit price shall prevail and the total price shall be corrected (unless in the opinion of the purchaser there is an obvious error in the unit rate, in which case the total price against item would prevail and unit rate shall be corrected accordingly). If the supplier does not accept the correction of the errors, its Bid will be rejected. If there is a discrepancy between words and figures, the amount in words will prevail.
- 17.3 The Purchaser may waive any minor informality or non-conformity or irregularity in a bid, which does not constitute a material deviation, provided such a waiver does not prejudice or offers the relative ranking of any Bidder.
- 17.4 Prior to the detailed evaluation, pursuant to ITB Clause 18, the Purchaser will determine the substantial responsiveness of each bid to the bidding documents. For purposes of these Clauses, a substantially responsive bid is one which conforms to all the terms and conditions of the bidding documents without material deviations. Without prejudice to the generality of the foregoing deviations from or objections or reservations to critical provisions such as those concerning Performance Security (GCC Clause 6) Warranty (GCC Clause 26). Force Majeure (GCC Clause 17), Applicable law (GCC Clause 22) and Taxes & Duties (GCC Clause 24) will be deemed to be a material deviation. The Purchaser's determination of a bid's responsiveness is to be based on the contents of the bid itself.

In case of any deviation to the Warranty (GCC Clause 26), Force Majeure (GCC Clause 17), Applicable law (GCC Clause 22) and Taxes & Duties (GCC Clause 24) in the Techno-commercial/ Price Bid, **the Bid Form, signed by the Bidder which stipulates acceptance of all the terms & conditions of tender document, shall supersede all other terms & conditions given in the tender by the Bidder.**

- 17.5 In normal circumstances if a bid is not substantially responsive, it will be rejected by the purchaser.

**18. EVALUATION AND COMPARISON OF BIDS:**

- 18.1 The Purchaser will evaluate and compare the Bids on the basis of techno-commercial evaluations followed by price bid evaluation.

19. **CONTACTING THE PURCHASER:**

19.1 Subject to Clause 16, no Bidder shall contact the Purchaser on any matter relating to its Bid from the time of the Bid opening to the time the contract is awarded.

19.2 Any effort by a Bidder to influence the Purchaser in the Purchaser's bid evaluation, Bid comparison or contract award decisions may result in the rejection of the Bidder's Bid.

20. **AWARD OF CONTRACT:**

20.1 **AWARD CRITERIA:**

Subject to Clause 22, the Purchaser will award the contract to the successful Bidder whose Bid has been determined to be techno commercially acceptable and lowest, provided further that the Bidder is determined to be qualified to perform the contract satisfactorily.

21. **PURCHASER'S RIGHT TO VARY QUANTITIES AT TIME OF AWARD:**

The Purchaser reserves the right at the time of award of contract to increase/decrease the total quantity of Goods and services for which bids have been invited by up to 25% of their value.

22. **PURCHASER'S RIGHT TO ACCEPT OR REJECT ANY OR ALL BIDS:**

The Purchaser reserves the right to accept or reject any Bid and annul the Bidding process and reject all Bids at any time prior to award of contract, without thereby incurring any liability to the affected Bidder or Bidders or any obligation to inform the affected Bidder or Bidders of the grounds of the purchaser's action. The purchaser is not bound to accept the lowest or any bid.

23. **NOTIFICATION OF AWARD AND SIGNING OF CONTRACT:**

23.1 Prior to the expiry of the period of Bid validity, the Purchaser will notify the successful Bidder by registered post/fax that its Bid has been accepted by enclosing detailed order copy in duplicate. This will constitute the formation of the contract and date of the contract shall be the date of each notification.

23.2 Upon the successful Bidder's returning back one copy of the order within 3 days duly stamped and signed as token of acceptance of the order on the said laid out terms and conditions and also furnishing to Performance Security i.e. Security Deposit pursuant to Clause 24, the Purchaser will promptly discharge Bid Security of successful bidder, pursuant to Clause 9, and also discharge Bid Security of unsuccessful bidders, pursuant to clauses 9.5.

24. **PERFORMANCE SECURITY:**

24.1 Within 10 days of the date of notification under Clause 23.1 the Successful Bidder shall furnish the Performance Security/Security Deposit for 10% of the contract price in the

form of a Demand Draft drawn in favour of HSCC (India) (I) Ltd. payable at Noida or New Delhi from a Nationalised/ 1<sup>st</sup> Class/ Scheduled bank.

24.2 Failure of the successful Bidder to comply with the requirement of Clause 23 and Clause 24 shall constitute sufficient grounds for the annulment of the award and the Contract and forfeiture of the Bid Security, in which event the Purchaser may make the award to the next lowest Bidder or call for new Bids.

25. **LOCAL CONDITIONS:**

It will be imperative on each Bidder to fully acquaint himself of all the local conditions and factors that would have any effect on the performance of the contract and cost of the Goods. The Purchaser shall not entertain any request for clarifications from the Bidder regarding such local conditions. No request for the change of price, or time schedule of delivery of Goods shall be entertained after the Purchaser accepts the Bid.

**Chief General Manager (PG-I)**

## SECTION-II

### GENERAL CONDITIONS OF CONTRACT (G.C.C.)

#### 1. DEFINITIONS:

1.1 In this contract, the following terms (whether or not spelled with an initial capital letter) shall unless the context otherwise requires be interpreted as indicated.

- (a) "The contract" (or "this contract") means the agreement entered into between the Purchaser and the Supplier, as recorded in the Contract Form signed by the parties, including all attachments and appendices thereto and all documents incorporated by reference therein and includes the Instructions to Bidders (ITB).
- (b) "The Contract Price/All inclusive lump sum Price" means the price payable to the supplier under the contract for the full and proper performance of its contractual obligations;
- (c) "The Goods" means all of the equipment, machinery, and/or other materials, which the Supplier is required to supply to the Purchaser under the contract;
- (d) "Services" means services ancillary to the supply of the Goods, such as transportation and insurance, and any other incidental services;
- (e) "The Purchaser" means the organisation purchasing the Goods i.e., Directorate of Ayurveda, Govt. of Rajasthan, Ajmer acting through their Consultants HSCC (I) Ltd.
- (f) "The Supplier" means the individual or firm supplying the Goods and services under this contract;
- (g) "Consignee" means where the Goods are required to be delivered at the destination(s), i.e. Consignees as designated by Directorate of Ayurveda, Govt. of Rajasthan, Ajmer (i.e. Six Divisional Head Quarters & Four Pharmacies).

#### 2. APPLICATION:

2.1 These General "Conditions" shall apply to the extent that provisions in other parts of contract do not supersede them.

#### 3. STANDARDS:

3.1.1 The Goods supplied under this contract shall conform to the standards mentioned in the Technical Specifications, and, when no applicable standard is mentioned, to the authoritative standard appropriate to the Goods and such standards shall be the latest issued by the concerned institution.

4. **USE OF CONTRACT DOCUMENTS AND INFORMATION:**

- 4.1 The Supplier shall not, without the Purchaser's prior written consent, disclose the contract or any provision thereof, or any specification, plan, drawing, pattern sample, or information furnished by or on behalf of the Purchaser in connection therewith, to any person other than a person employed by the Supplier in the performance of the contract. Disclosure to any such employed person shall be made in confidence and shall extend only so far, as may be necessary for purposes of such performance.
- 4.2 The Supplier shall not, without the Purchaser's prior written consent, make use of any documents or information enumerated in para 4.1 except for purposes of performing the contract.
- 4.3 Any document, other than the contract itself enumerated in para 4.1 shall remain the property of the Purchaser and shall be returned (in all copies) to the Purchaser on completion of the Supplier's performance under the contract if so required by the Purchaser.

5. **PATENT RIGHTS:**

- 5.1 The Supplier shall indemnify the Purchaser against all third party claims of infringement of patent, trademark, or industrial design right arising from use of the Goods or any part thereof.

6. **CONTRACT PERFORMANCE SECURITY (SECURITY DEPOSIT):**

- 6.1 Within 10 days after the Supplier's receipt of award notification and order copies of the contract, the Supplier shall furnish performance Security to the Purchaser in the amount specified (IFB) in the document.
- 6.2 The Performance Security as deposited by the supplier shall be used by the purchaser as compensation for any loss or any dues recoverable from the supplier (including liquidated damages where applicable) resulting from the Supplier's failure to complete its obligations under the contract. The Purchaser may retain the whole or such part of it as it considers to be sufficient compensation for such loss. In such an event the balance amount (if any) shall be returned to the supplier not later than the expiry of the period stated in clause 6.3.
- 6.3 The Performance Security unless deposited under GCC clause 6.2 will be discharged by the purchaser not later than 30 days following the date of completion of the suppliers performance obligations, including the warranty obligations under the contract.

7. **INSPECTION & TESTS:**

- 7.1 The Purchaser or its representative shall have the right to inspect and/or to test the Goods to confirm their conformity to the contract. The Special Conditions of Contract and/or the Technical Specifications specify what inspection and tests the Purchaser requires and where they are to be conducted then such specification shall be complied with for the

Goods to which it applies. The Purchaser shall notify the Supplier in writing of the identity of any representative retained for these purposes.

- 7.2 The inspection and tests may be conducted on the premises of the Supplier or its Sub-Supplier (s) at point of deliver and/or at the Goods' final destination. Where conducted on the premises of the Supplier or its Sub-Supplier(s), all reasonable facilities and assistance including access to drawings and production data - shall be furnished to the inspectors at no charge to the Purchaser.
- 7.3 Should any inspected or tested Goods fail to conform to the specifications, the Purchaser may reject them and the Supplier shall either replace the rejected Goods or make all alterations necessary to meet specification requirements free of cost to the Purchaser.
- 7.4 The Purchaser's right to inspect, test and where necessary reject the Goods after the Goods' delivery to the Consignee shall in no way be limited or waited by reasons of the Goods having previously been inspected, tested and passed by the Purchaser or his representative prior to the Goods, shipment.
- 7.5 Nothing in Clause 7 shall in anyway release the Supplier from any warranty or other obligations under this contract.

8. **PACKING:**

- 8.1 The Supplier shall provide such packing of the Goods as is required to prevent their damage or deterioration during transit to their final destination as indicated in the contract. The packing shall be sufficient to withstand without limitation, rough handling during transit and exposure to extreme temperature, salt and precipitation during transit and open storage. Packing case size and weights shall take into consideration, where appropriate the remoteness of the Goods' final destination and absence of heavy handling facilities at all points in transit.
- 8.2 The packing marking shall show the description of quantity of contents, the name of the consignee and address, the gross weight of the packages, the name of the supplier with a distinctive number of mark sufficient for purposes of identification. Each package shall contain:
  - (a) a packaging note quoting the name of the purchaser
  - (b) the number and date of order
  - (c) nomenclature of the goods
  - (d) schedule of parts for each complete equipment giving part number with reference to assembly
- 8.3 Notwithstanding anything stated in this clause, the supplier shall be entirely responsible for loss, damage, deterioration, and depreciation of the goods due to faulty protective & insecure packing and shall arrange for prompt replacement.

9. **DELIVERY:**

9.1 **Delivery of the Goods shall be made by the Supplier within 8 weeks** from the date of contract (or from the date of establishing Letter of Credit in favour of the Principals in case of imported origin Goods) **unless specified in IFB** and installation and commissioning to be done wherever applicable within 7 days thereafter. In case spare parts and tools are also ordered with the Goods, the Bidder will undertake to offer spare parts and tools for delivery along with the main Goods only and not before.

10. **INSURANCE:**

10.1 The Goods supplied under the contract shall be fully insured including transit insurance against various risks as required or approved by the Purchaser arising out of transportation, storage, delivery, erection, installation, testing and commissioning at his cost up to delivery at site. Insurance policy shall be valid upto date of commissioning. Proof of Insurance shall be made available before issuance of dispatch clearance.

10.2 For delivery of goods at site, the insurance shall be obtained by the supplier in an amount equal to 110% of the value of the goods from "Ware house to ware house" (final destination) on "all risks" basis including war, risks, strikes, erection, storage etc. In any event the Goods are at the suppliers risk until delivery to site.

11. **TRANSPORTATION:**

**To be arranged by the supplier up to consignee duly insured.**

12. **PAYMENT:**

Both for Indian origin goods and for import origin goods. To be read in conjunction with clause 6.0 of ITB.

12.1 The Supplier's request (s) for payment shall be made to the Purchaser in writing, accompanied by an invoice describing as appropriate, the Goods delivered and Services performed and by shipping documents, such Goods to be duly certified and wherever applicable supported with documentary evidence in support there of Satisfactory installation duly certified by authorised personnel of Purchaser shall accompany for release of balance payment.

12.2 **FOR INDIGENOUS GOODS:**

i) 90% of the invoice value will be made within 15 days of documentary proof of receipt of the invoiced goods at consignee end (i.e. Consignee Receipt Certificate) along with necessary documents like transport, transit insurance etc.

- ii) Balance 10% payment subjected to clause 6.1 of ITB will be released within 15 days, upon receipt of satisfactory Installation & Commissioning Certificate, where ever required, from Concerned Authorities.

### 12.3 **FOR IMPORT ORIGIN GOODS:**

Payment will be made by opening of Irrevocable Letter of Credit in favour of the foreign supplier. The amount of Indian Agency Commission if, any, out of FOB price will be deducted from the C.I.F L/C value, and this Agency Commission shall be paid in equivalent Indian Currency in India to the Indian agent, subject to clause 6.1(c) of ITB after receipt of satisfactory installation & commissioning report of the equipment. Irrespective of the agency commission, **10% of FOB Price will be deducted and L/C opened for net of C.I.F value.** This L/C will have provisions for release of this deducted amount subject to clause 6.1(c) of ITB only after receipt of satisfactory acceptance report, satisfactory Installation & Commissioning Certificate from Consignee, where ever required.

- 12.4 The stores (both Indians & Import origin goods) should be despatched only after ensuring prudent inspection carried out from ISO Certified Inspection Agencies/LLOYDS/ SGS etc. and proof of such documents submitted. Foreign manufacturers having ISO certification are themselves authorized to issue inspection certificate along with inspection certificate from third party Inspection Agencies viz. LLOYDS/ SGS etc.

- 12.5 Payment for turn-key activities shall be released in full on completion of the activity.

### 13. **PRICES:**

- 13.1 Prices charged by the Supplier for Goods delivered and Services performed under the contract shall not vary from the prices quoted by the Supplier in its Bid.
- 13.2 In receipt of offer in foreign currency, the exchange rate prevailing on the date of opening of bid (Techno Commercial bid) shall be taken for comparison of bid prices.

### 14. **DELAYS IN THE SUPPLIER'S PERFORMANCE:**

- 14.1 The time and the date specified in the Contract for the delivery of the Goods shall be deemed to be the essence of the Contract.
- 14.2 Delivery of the Goods and performance of Services shall be made by the Supplier in accordance with the time schedule specified by the Purchaser.
- 14.3 An unexcused delay by the Supplier in the performance of its delivery obligations shall render the Supplier liable to any or all of the following sanctions, forfeiture of its Performance Security in accordance with Clause 6.2, imposition of liquidated damages and/or termination of the Contract for default.
- 14.4 If at any time during performance of the Contract, the Supplier or its sub-Supplier (s) should encounter conditions impeding timely delivery of the Goods and performance of the Services, the Supplier shall promptly notify the Purchaser in writing of the fact of the

delay, its likely duration and its cause(s). As soon as practicable after receipt of the Supplier's notice the Purchaser shall evaluate the situation and may at its discretion extend the supplier's time for performance by such period as the purchaser may think fit and shall in the case of Force Majeure extend such time by such period as the Purchaser shall consider fair and reasonable. Clause 14.1 stands extended to include this.

15. **LIQUIDATED DAMAGES:**

15.1 Subject to force majeure, if the Supplier fails to deliver any or all of the Goods or perform the Services within the time period(s) specified in the Contract the Purchaser shall, without prejudice to its other remedies under the Contract or extended under clause 14.3, deduct from the Contract price, as Liquidated Damages, a sum equivalent to **0.5% of the price of the delayed Goods or unperformed Services for each week of delay until actual delivery or performance, up to a maximum deduction of 10% of the value of the delayed portion of work.** Once the maximum is reached, the Purchaser may consider termination of contract.

16. **TERMINATION FOR DEFAULT:**

16.1 The Purchaser may, without prejudice to any other remedy for breach of Contract, by written notice of default sent to the Supplier, terminate the Contract in whole or in part.

(a) If the Supplier fails to deliver any or all of the Goods within the time period(s) specified in the Contract, or any extension thereof granted by the purchaser pursuant to Clause 14, or

(b) If the Supplier fails to perform any other obligation(s) under the Contract.

16.2 In the event the Purchaser terminates the Contract in whole or in part, pursuant to para 16.1, and without prejudice to the Purchaser's other remedies, the Purchaser may procure, upon such terms and in such manner as it deems appropriate, Goods or Services similar to those undelivered or unperformed and the Supplier shall be liable to the Purchaser for any excess costs for such similar Goods. However, the Supplier shall continue performance of the Contract to the extent not terminate.

17. **FORCE MAJEURE:**

17.1 Notwithstanding the provisions of Clauses 6,14,15,16, the Supplier shall not be liable for forfeiture of its Performance Security, liquidated damages or termination for default if and to the extent that it's delay in performance or other failure to perform its obligations under the Contract is the result of an event of Force Majeure.

17.2 For purposes of this clause and clauses 14.3, 15.1 & 17.3 "Force Majeure" means an event beyond the control of the Supplier and not involving the Supplier's fault of negligence and not foreseeable. Such events may include but are not restricted to, acts of the Purchaser either in its sovereign or contractual capacity, wars or sovereign or contractual capacity wars or revolutions, fires, floods, epidemics, quarantine restrictions and freight embargoes.

- 17.3 If a Force Majeure situation arises, the Supplier shall promptly notify the Purchaser in writing of such condition and the cause thereof. Unless otherwise directed by the Purchaser in writing, the Supplier shall continue to perform its obligations under the Contract as far as is reasonably practicable and shall seek all reasonable alternative means for performance not prevented by the Force Majeure event.
18. **TERMINATION FOR INSOLVENCY:**
- 18.1 The Purchaser may at any time terminate the Contract by giving written notice to the Supplier, without compensation to the Supplier, if the Supplier becomes bankrupt or otherwise insolvent (which events shall of themselves be a breach of the contract on the part of the supplier), provided such termination will not prejudice or affect any right of action or remedy which has accrued or will accrue thereafter to the Purchaser.
19. **TERMINATION FOR CONVENIENCE:**
- 19.1 The Purchaser may, by written notice sent to the Supplier, terminate the Contract, in whole or in part, at any time for its convenience. The notice of termination shall specify that termination is for the Purchaser's convenience, the extent to which performance of work under the contract is terminated and the date upon which such termination becomes effective.
- 19.2 The goods that are complete and ready for shipment within 20 days after the Supplier's receipt of notice of termination shall be purchased by the Purchaser at the Contract terms and prices. For remaining Goods the Purchaser may elect:
- (a) To have any portion completed and delivered at the Contract terms and prices; and/or
  - (b) To cancel the reminder and pay to the Supplier an agreed amount for partially completed Goods and for materials and parts previously procured by the Supplier.
20. **RESOLUTION OF DISPUTE**
- 20.1 The Purchaser and the Supplier shall make every effort to resolve amicably by direct informal negotiation any disagreement or dispute arising between them under or in connection with the Contract.
- 20.2 If, after thirty (30) days from the commencement of such informal negotiations, the Purchaser and the Supplier have been unable to resolve amicably a Contract dispute either party may require that the dispute be referred for resolution to the Indian Arbitration by Indian Council of Arbitration in accordance with the Arbitration & Reconciliation Act 1996 with latest amendments if any.
- 20.3 Venue of Arbitration shall be at NOIDA, U.P./New Delhi
21. **GOVERNING LANGUAGE:**
- 21.1 The Contract shall be written in the language of the Bid (English Language) as specified

by the Purchaser. All correspondence and other documents pertaining to the Contract, which are exchanged by the parties, shall be written in that same language.

22. **APPLICABLE LAW:**

22.1 The Contract shall be interpreted in accordance with the laws of Union of India.

23. **NOTICES:**

23.1 Any notice given by one party to the other pursuant to the contract shall be sent in writing or by telegram or cable and confirmed in writing to the address specified for that purpose in the Special Conditions of Contract.

23.2 A notice shall be effective when delivered or on the Notice's effective date, whichever is later.

24. **TAXES AND DUTIES:**

24.1 Supplier shall be entirely responsible for all taxes, duties, license fees etc. incurred until delivery of the contracted Goods to the Purchaser.

25. **The Bid Security of successful tenderers will be released after receipt of contract performance security and contract formation under clause of 23.1 of ITB.**

26. **WARRANTY (For Equipment, Accessories, Software & Hardware):**

26.1 The supplier warrants that the Goods supplied under this Contract are new, unused, of the most recent of current models and incorporate all recent improvements in design and materials **both in Hardware and Software**, unless other wise provided in the Contract. The supplier further warrants that the Goods supplied under this Contract shall have no defect arising from design, materials or workmanship or from any act or omission of the Supplier that may develop under normal use of the supplied Goods in the conditions prevalent in India.

26.2 This warranty shall remain valid (subject to clause 26.4) for 12 months after the Goods have been satisfactorily installed & commissioned as duly certified by the appropriate authority, whichever is earlier.

26.3 The Purchaser shall promptly notify the supplier in writing of any claim arising under this warranty.

26.4 Upon receipt of such notice, the supplier shall, with all reasonable speed, repair or replace the defective Goods or parts thereof, free of cost at the site. The Supplier shall take the replaced parts/goods at the time of their replacement. No claim whatsoever shall lie on the purchaser for the replaced parts thereafter. The warranty period will stand extended accordingly.

- 26.5 If the Supplier having been notified fails to remedy the defect (s) within a reasonable period, the purchaser may proceed to take such remedial action as may be necessary, at the Supplier's risk and expense and without prejudice to any other rights which the Purchaser may have against the Supplier under the Contract or in Law.
- 26.6 The Purchaser reserves the right to reject any set of equipment found defective within 30 days after the date of acceptance of equipment. The cost towards replacement will have to be borne by the supplier.
- 26.7 Nothing in this clause 26 shall affect the Purchaser's other rights under the Contract or in Law.

## **27 INSPECTION & TEST PROCEDURES:**

- (i) The Stores will be inspected at Purchaser's sole discretion before packing at the manufacturer's premises and on receipt at site by Purchaser's nominated representatives. The decision of Purchaser in the matter of acceptability of the stores will be final and binding. In case Purchaser desires, the demonstration/inspection and trials/testing will have to be got conducted at site at no extra cost.

## **28 SUPPLY, INSTALLATION AND COMMISSIONING AND WARRANTY SERVICING: (IN RESPECT OF EQUIPMENTS)**

The Supply, Installation and Commissioning of the equipment & trial run have to be done at site by the supplier/or his authorised agent. No additional charges for installation and commissioning will be paid. The Supplier and Indian agent shall be liable for this service for goods of import origin.

## **29 TRAINING: (If required)**

Free demonstration, operational and maintenance training will have to be provided at the site of installation to the assigned personnel, during trial period.

## **30 MANUALS:**

The Supplier has to provide **three sets** of operation manuals and maintenance manuals along with each equipment to each consignee and one set of Operation & Maintenance Manual is to be provided to Purchaser while claiming 90% payment. The maintenance manual should give details up to component level and the faultfinding procedure with detailed illustrations.

## **31 JURISDICTION:**

All disputes arising out of the contract shall (subject to clause 20) be subject to the jurisdiction of the appropriate court at NOIDA/ New Delhi only.

### **Special Note: (Forming part of SCC).**

- i) Purchaser is not bound to accept the lowest tender or any tender or to assign any reasons for non-acceptance.

- ii) Purchaser reserves right of selection of equipment without restrictions to price factor alone.
- iii) Purchaser also reserves its right to split an order on more than one party as it deems fit in respect or order for any item.

**Executive Director (Proc. & PG-I)**

**SECTION-III**  
**SPECIAL CONDITIONS OF CONTRACT**

The following Special Conditions of Contract shall supplement the General Conditions of Contract. Whenever, there is a conflict, the provisions herein shall prevail over the General Conditions of Contract.

1. The Performance Security unless deposited under GCC Clause 6.2 will be discharged by the purchaser not later 30 days following the date of completion of the supplier's performance obligations, including the Warranty obligations under the contract.
2. Insurance: For delivery of goods at site, the insurance including transit insurance shall be obtained by the supplier in an amount equal to 110% of the value of the goods from "warehouse to warehouse" (final destination) on "all risks" basis including war, risks, strikes, erection, storage etc. In any event the Goods are at the Supplier's risk until delivery to site.
3. For Import origin goods quoted, the Supplier or the Indian agent shall have to arrange at his own cost for all import/custom clearance handling formalities. Purchaser upon advance notice from supplier shall only provide the CDEC (Custom Duty Exemption Certificate), Octroi Exemption Certificate, etc. wherever required.
4. **A. Minimum Qualification Criteria (For Equipments):**

Qualifying Minimum Requirements:

(To be supported with documentary evidence strictly as per instructions given as foot-note under Proforma for Performance Statement)

- i) Bidder should be a regular manufacturer or an authorised Indian agent for the type of stores offered.
- ii) An authorised Indian agent could be only for imported origin equipment duly authorized by the foreign principal quoting through the Indian agent.
- iii) Indigenous Manufacturers to quote themselves and not through any agent.

**In case of a Item comprising group of items, then Bidder may give Self Manufacturer's authorisation for main equipment and for associated equipment from other manufacturers of his choice (indigenous/imported) for which Bidder shall submit Manufacturer's Authorization as per the Tender format.**

- iv) Bidders should have in the past 5 years, satisfactory executed for the **Item** offered, at least one single order of like nature of item and **quantity not less than 80%** of quantity of **Item** offered by bidder. The Bidders shall furnish "End User Certificate" indicating contract details i.e. name of person, phone/fax /mobile nos. etc. Bidders shall also certify that they have not supplied equipment with similar specification to any other organisation, at prices lower than the rates offered in response to the present IFB.
- v) Foreign bidder's performance report shall include same Indian agent by which this current bid is quoted.

- vi) Alternatively foreign bidders performance in India could be seen in isolation in the event of quoting through new Indian agent duly authorized by him.

**B. Other eligibility requirements:**

- i) Bidder should have a present installed capacity/sales capacity to match the delivery requirements.
- ii) **The Bidder should submit audited balance sheet and Profit & Loss Account alongwith audited report for the last 3 years to enable the purchaser to assess the financial capability of the bidder or positive net worth of the bidder.**

Notwithstanding anything stated above, the purchaser reserves the right to assess the capability and capacity of bidder to perform the contract.

- iii) Clause 13 shall apply for the relevant items.

5. Five years Performance Statement: Bidders should give performance statement of orders for similar **Item(s)** satisfactorily executed to sizeable value both in quantity & cost in comparison to **Item** offered in the price bid.

6. **Bid Form: To be submitted by all bidders as per format enclosed:**

7. **Deleted**

8. **Deleted**

9. **Miscellaneous:**

- a) While quoting for the **Item(s)**, all components and quantities specified in the **Item(s)** must be quoted. The purchaser will evaluate bid on an individual **Item** wise basis. **The bid shall stand rejected if all the components and quantities specified in any Item(s) are not quoted.**
- b) **Evaluation will be made on the basis of total all inclusive lump sum price value offered for the Schedule.**
- c) The break up of “all inclusive lump sum price” of the **Schedule**; is also to be furnished in the price offered by bidder.
- d) i) Bidders are requested to quote for the proven and time tested renowned brands of equipment/accessories having countrywide reputation and acceptance. The Purchaser, however, reserves the right to decide on it’s own as to which of the brand/makes quoted by the bidders are to be considered or not to be considered as proven/reputed, for the purpose of evaluation.

- ii) No bidder for the purpose of offering lowest price shall quote for local brands/refurbished/ reconditioned stores, which are not time tested, as these would be liable for rejection.
  - iii) Although bidder may quote for more than one brand for the same price, the purchaser shall have the right to select the brand amongst alternatives quoted and its decision will be binding on the bidder.
  - iv) **Bidder in their own interest can quote for items and services separately if in the view of bidder, the purchaser unknowingly omitted or expressly not indicated the requirements of items/services without which, the commissioning or acceptance or otherwise of the equipment of the bidder will be a doubtful proposition.**
- e) Deleted.
- f) The Supplier directly or through his Indian agent wherever applicable will be liable for the contractual obligation including delivering the ordered goods and for undertaking satisfactory installation and commissioning etc. including warranty servicing.
10. Bidders are to inspect the site premises and the proposed place of installation of equipment and certify their satisfaction that the proposed site is suitable and compatible for the installation of the offered unit. Bidder may take up with consignee for their site visit.
11. Bidders are to ascertain normal power supply fluctuation range and to certify that it is compatible with the offered unit of equipment. A guarantee to such effect should be offered by each bidder along with details of electrical appliances proposed to be deployed for taking care of such fluctuation.
12. Bidder's offer should be on a "Turn Key" basis for inclusion of all costs incidental to the same.
13. Deleted
14. The substantial responsiveness of bidder will be determined as per Purchaser's own qualitative internal assessment in consultation with consignee, and with reference to bidders reasonable level of compliance to various stipulated terms and conditions in the Bidding Documents, Compliance to submission of various documentary supporting evidence, other related information along with the bid, the degree of performance status, and high order value execution for prestigious good clients etc. weight age given to bidder on qualitative basis by the evaluation committee, besides other merits of the bidder such as proven source market reputation, past experience and feed back gained in respect of bidder etc. Accordingly, in line with the above, the purchaser reserves the right as not liable to bidder on account of this prudent internal assessment and that bidder shall have not claims whatsoever.
15. Besides must take into consideration in its bid, costs to be incurred for any additional work pertaining to civil, Electrical, Plumbing, sanitary, Radiation protection as per Govt. regulation, furniture, servo stabilisers, U.P.S. etc. required for successful installation testing and commissioning of the system and the "All inclusive lump sum price" should include all such

costs, each **Item** is to be considered a package in itself and suppliers to execute the order package on a “turn key basis”.

16. Every effort has been taken to put forth general specifications in these bidding documents. If inadvertently, any of the specification drawn happens to match with the specifications of any one particular firm’s product only, in respect of critical parameters, than it will not automatically mean that this particular firm’s offer is only technically suitable. In general, the specifications offered by other firms will be assessed in their own entirety to ascertain whether or not the board functions in general expected of the equipment are available with reasonable tolerance on the desired requirements of the purchaser and accordingly the offers would be considered based on prudent assessment of the purchaser.
17. Bidders who have paid the Bid Document Fee as per Clause 9[B] of ITB are only eligible to quote.
18. The supplier/manufacturer shall be made responsible for organising timely clearance/delivery of the equipment from the custom authorities by appointing custom agent, if necessary, and shall also arrange to transport the equipment to the destination including installation and commissioning of the same. Necessary insurance shall also be arranged by the supplier/manufacturer covering all these activities including transit insurance from destination to destination.
19. To ensure timely completion of project, in the event of receipt of only one bid or few bids received for any **Item(s)** not fully meeting all tendered conditions, then the tender committee constituted could take prudent decision to accept the offer(s) which first comply by legitimately relaxing any one non stringent condition without affecting major functional requirement.
20. **The following clause needs to be read in conjunction with Clause 6 of ITB and Clause 26.2 of GCC & will prevail upon the description given for warranty elsewhere in the tender document/ with Equipment Specifications:**

**Warranty for Medical Equipments:**

“Supplier/ Manufacturer should provide 12 months full onsite comprehensive warranty with spares from the date of installation. Warranty will start only from the date of final acceptance of the machine at the department and price quoted inclusive of these criteria.

21. Bidders should provide list of consumables and standard spare parts separately in the Techno-commercial Bid along with details of source of supply.
22. The Medical Equipments to be supplied to **6 Divisional Head Quarters** of Directorate of Ayurveda, Govt. of Rajasthan.

The **Machinery** to be distributed to **4 Pharmacies** of Directorate of Ayurveda, Govt. of Rajasthan.

Division and Pharmacy wise distribution will be provided along with Notification of Award.

**Executive Director (Proc. & PG-1)**

## **FORMATS**

## BID FORM

To: (Name and address of Purchaser)

IFB Ref.: .....

ITEM(S) Ref.: .....

**Having examined the Bidding Documents including if any Addenda Nos. issued \_\_\_\_\_, the receipt of which is duly acknowledged, we, the undersigned, offer to supply and deliver..... (Description of Goods and Services) in conformity with said bidding documents.**

We, undertake, if our bid is accepted, to deliver the goods in accordance with the delivery schedule specified.

**If our bid is accepted, we will submit performance security in a sum of equivalent to 10% of the Contract Price for the due performance of the contract.**

We agree in consideration of Rs.100/- if demanded to abide by this bid for a period of 180 (one hundred eighty) days after the date fixed for bid opening and it shall remain binding upon us and may be accepted at any time before the expiration of that period.

Until a formal contract is prepared and executed, this bid together with your written acceptance thereof shall constitute a binding contract between us.

We confirm that stipulated Bid Security is enclosed herewith as a part of bid.

We understand that you are not bound to accept the lowest or any bid you may receive.

We accept all your terms and conditions stipulated in this tender document without deviations, both technical & techno-commercial.

Dated this..... Day of.....  
200.....

\* Applicable for Equipments only.

---

(Signature)

(In the capacity of)

Duly authorised to sign Bid for and on behalf of

\_\_\_\_\_  
Signed

## CONSIGNEE RECEIPT CERTIFICATE

(To be given by consignee's authorised representatives)

The following Goods (Quantity mentioned against each) has/have been received in good conditions along with a copy of inspection report.

1. Name of items supplied .....  
Against Purchaser's P.O. ref. dated.....

Total :

Date of Receipt of Goods:

Place:

\_\_\_\_\_  
(Authorised Representative)/ Consignee

**MANUFACTURERS' SELF AUTHORIZATION FORM**

No. \_\_\_\_\_ dated \_\_\_\_\_.

To

\_\_\_\_\_  
\_\_\_\_\_  
\_\_\_\_\_  
\_\_\_\_\_

Dear Sir,

IFB NO. \_\_\_\_\_.

We \_\_\_\_\_ who are established and reputable manufacturers of \_\_\_\_\_ (name and description of goods offered) having factories at \_\_\_\_\_ (address of factory) do hereby submit a bid, and sign the contract with you against the above IFB. No.....

No company or firm or individual other than M/s \_\_\_\_\_ (name of the manufacturer) are authorised to bid, and conclude the contract in regard to this business, against this specific IFB.

We hereby extend our full guarantee and warranty as per Clause 26 of the General Conditions of Contract for the goods and services offered for supply by us against this IFB.

Yours faithfully,

(Name)

(Name of Manufacturers)

Note:- This letter of authority should be on the letterhead of the manufacturer and should be signed by a person competent and having the power of attorney to bind the manufacturer. It should be included by the Bidder in its bid.

**MANUFACTURERS' AUTHORIZATION FORM**

No. \_\_\_\_\_ dated \_\_\_\_\_.

To

\_\_\_\_\_  
\_\_\_\_\_  
\_\_\_\_\_  
\_\_\_\_\_

Dear Sir,

IFB.No. \_\_\_\_\_.

We \_\_\_\_\_ who are established and reputable manufacturers of \_\_\_\_\_ (Name and Description of Goods offered) having factories at \_\_\_\_\_ (Address of Factory) do hereby authorize M/s \_\_\_\_\_ (Name & Address of the Agent) to submit a bid, and sign the contract with you against the above IFB. No.....

No company or firm or individual other than M/s \_\_\_\_\_ (Name of the Agent) are authorised to bid, and conclude the contract in regard to this business, against this specific IFB.

We hereby extend our full guarantee and warranty as per Clause 26 of the General Conditions of Contract for the goods and services offered for supply by the above firm against this IFB.

Yours faithfully,

(Name)

(Name of Manufacturers)

Note:- This letter of authority should be on the letterhead of the manufacturer and should be signed by a person competent and having the power of attorney to bind the manufacturer. It should be included by the Bidder in its bid.

**Proforma for Performance Statement (for a period of last five years)**

(Please read foot-note below)

Name of Item offered \_\_\_\_\_ Date of Opening \_\_\_\_\_ Time \_\_\_\_\_ Hours \_\_\_\_\_

Name of the Firm \_\_\_\_\_

Order placed by (full address of Purchaser)	Order No. and date	Description and quantity of Goods ordered	Value of order	Date of completion of delivery as per contract	Remarks indicating reasons for late delivery if any	Has the stores been satis- factorily supplied? (Attach a certificate from the Purchaser\ Consignee)	
1	2	3	4	5	6	7	8

Signature and seal of the Bidder \_\_\_\_\_

Note: This form will be considered complete only if duly filled and supported with proof of order copies, satisfactory order execution certificates from client and other relevant details enclosed with this form and same shall be applicable for assessing single order execution criteria as per SCC clause 4A (iv) of this document.

This information to be filled in as per the following format by all the bidders for each equipment bid by them and duly signed and to be submitted along with the techno-commercial bid:

Schedule Ref. (1)	Name of the Equipment with Tender Specifications (2)	Compliance of parameter/ specification (3)	Non-Compliance of parameter/ specification (4)	Remarks for Sr.No.(4) (5)

The information given above is factual & based on product specification details as per the latest catalogues/ product data sheets and technical literature enclosed.

**Signature of the bidder & seal:**

**PRICE SCHEDULE**

**A) Price Schedule For Domestic Goods OR Goods of Foreign Origin Located Within India**

1	2	3	4	5						6	
Schedule	Brief Description of Goods	Country of Origin	Qty. (No.)	Ex-factory/ Ex-Warehouse/ Ex-Showroom/ Off the Shelf	Excise Duty (if any) – In % or value	Sales Tax/CST against / VAT/ CENTVAT (if any) – In % or value	Packing & Forwarding charges	Inland Transportation, Insurance, Loading/unloading,, Incidental Costs till Consignee's Site	Incidental Services (including Insurance, Installation & Commissioning Supervision, Demonstration & Training) at Consignee's Site	Total Unit Price (Rs.) =a+b+c+d +e+f	Total Price (Rs.)
				5(a)	5(b)	5(c)	5(d)	5(e)	5(f)	5(g)	4x5(g)

Total Tender Price in Rupees:

In words:

- Note : 1. If there is a discrepancy between unit price & total price, THE UNIT PRICE shall prevail.  
 2. The bidder will be fully responsible for the safe arrival of the goods at destination (consignee's site) in good condition.

Signature of the Bidder :

Name :

Business Address :

Seal of Bidder :

Date :

Place :

**PRICE SCHEDULE**

**B) Price Schedule For Goods To Be Imported From Abroad**

1	2	3	4	5							6
Schedule	Brief Description of Goods	Country of Origin	Qty. (No.)	FOB Price at Airport/ Airport of Loading	CIF Price at Port/ Airport of Entry	Custom Duty amount with CDEC & NMIC if applicable 9to be reimbursed by the Purchaser)	Custom Clearance & Handling **	Inland Transportation, Insurance, Loading/ unloading,, Incidental Costs till Consignee's Site **	Incidental Services (including Insurance, Installation & Commissioning Supervision, Demonstration & Training) at Consignee's Site **	Total Unit Price = b+c+d +e+f	Total Price  4x5(g)
				5(a)	5(b)	5(c)	5(d)	5(e)	5(f)	5(g)	

\*\* To be paid in Indian Currency (Rs.)

Total Tender Price:

In words:

- Note : 1. If there is a discrepancy between unit price & total price, THE UNIT PRICE shall prevail.  
 2. The bidder will be fully responsible for the safe arrival of the goods at destination (consignee's site) in good condition.

Indian Agency Commission : ....% of FOB (Included/Excluded in above)

Custom Duty with CDEC & NMIC if applicable : .....% of CIF value- Column 5 (C)

Signature of the Bidder :

Name :

Business Address :

Seal of Bidder :

Date :

Place :

## **SCHEDULE OF REQUIREMENT**

## **Description & Specifications**

**BID REFERENCE: IFB No. HSCC/PUR/ISM-RAJ/2009/A Dated 25.03.2009**

**SCHEDULE OF REQUIREMENT & TECHNICAL SPECIFICATIONS OF MEDICAL EQUIPMENTS**

Sr. No.	Item Description	Technical specifications	Quantity in Nos.
1.	Dressing Drums	SS seamless ISI Marked 11"x 9" to meet IS: 3831 with latest Amendment.	156
2.	Instrument Sterilizers Table Model	12" x 6" x 4" Seamless thermostatic control with tray lifting system ISI marked to meet IS: 5022. With latest Amendment.	50
3.	Formalin Sterilizers	11"x 8"x 8" acrylic with 3 nos. of Sliding tray filled in leak proof cabinet	52
4.	Bowel Stand SS	MS frame. Doubles wash hand basin stand with two SS wash bowls. Powder coated frame. To meet IS: 1267 latest Amendment	156
5.	Revolving Stool	Three legs. Height adjustable 560mm to 800mm. SS top 300 mm dia to meet IS: 7081 with latest Amendment powder coated.	96
6.	Dissecting Scissor	Curved 6" SS both SS to meet IS: 9146.with latest Amendment.	52
7.	Dissecting Scissor	Straight 6" both blunt SS to meet IS: 9146. With latest Amendment.	52
8.	Needle holder (Mathieu's pattern)	6" fine SS to meet IS: 12841 (Part-1) with latest Amendment.	52
9.	Sponge Holding Forceps	6" SS to meet IS: 7735 with latest Amendment	156
10.	Halsted's Mosquito Forceps	Straight of SS to meet IS: 3644 with latest Amendment	104
11.	Halsted's Mosquito Forceps	Curved 5" SS to meet IS: 3645. with latest Amendment	104
12.	Spencer well's Haemostatic Forceps	6" straight SS to meet IS: 3645. with latest Amendment	156
13.	Spencer well's Haemostatic Forceps	6" curved SS to meet IS: 3645. With latest Amendment	156
14.	B. P. Instrument	ISI marked mercurial	100
15.	Stethoscope	Single tube Littman type superior to meet IS: 4513 with latest amendment	78
16.	B. P. Handel	No. 3 SS No.4 SS to meet IS:7120 with latest Amendment	46
17.	Scissor	Straight 6" SS made of 4 series to meet IS: 4513 with latest Amendment	125
18.	Scissor	Curved 6" SS made of 4 to meet IS: 4513 with latest Amendment	125
19.	Artery Forceps	Straight 6" SS to meet IS: 8175 with latest Amendment	206
20.	Artery Forceps	Curved 6" SS to meet IS: 8175 with latest Amendment	156
21.	E N T Set Complete (Otoscope)	(Otosepe) complete with fiber optic with battery handle and 4 reusable specula. to meet IS: 7007 with latest Amendment	51
22.	Tongue Depressor	SS to meet IS: 7756 with latest Amendment	50
23.	Foreign Body Remover Forceps	Brass 4" gun type	75
24.	Hot Water Rubber Bag	Both side ribbed to meet IS: 1867 with latest Amendment	48
25.	Torch	Two cell metallic ISI Marked	100

26.	Gas Stove (Two Burner )	Steel body IST marked with tube to meet IS: 1216 with latest Amendment	52
27.	Pestle Mortar	4" dia made of Iron	78
28.	Urinal Pot	SS male	48
29.	Catheter	Rubber No 3 to 8 meet IS: 7523 with latest Amendment	296
30.	Wheel Chair	AIS fame with metal sheet and back adjustable footrest, wheels with breaks and SS hopes overall length 100 mm. width 650-720 mm. height 910-950 mm seat height from floor 480 to 510 mm to meet IS: 6571 with latest Amendment	74
31.	Bed Screen with Curtain	MS frame, three fold on castor with hooks and curtains, powder coated to meet IS: 4458 with latest Amendment.	51
32.	Stretcher on Trolley	MS trolley frame power coated with 175 - 225 mm dia castors conforming to IS: 4035 with latest amendment and removable stretcher frame size overall 1985 mm x 565mm made of MS pipe dia 31.25 thickness 1 mm and bed made of MS sheet thickness 1.0 mm super imposed SS sheet of 0.8 mm thickness.	72
33.	Patient Examination Table	Made of CRCA sheet, complete with cabinet for storage of medicine, sliding doors. Three doors in upper section and swinging tray for BP app. Tilt table back rest with gas spring system size 185 x 50x80 cm apex. Power coated ISI marked	78
34.	X-ray view Box	For film	78
35.	Avagahan Koshta (Steam Room)	SS double walled 48x20x20 fitted with 0.5 kw heater and digital temperature controller. Jet massage through motor pump. Patient hold bar and bottom designed for body contour. ISO certified	52
36.	Pressure Cooker	10 Ltr. ISI marked to meet IS 2347 with latest Amendment.	52
37.	Bucket	15 Ltr. Made of G.I. sheet thickness 0.80 mm handle made of MS dia 8 mm	80
38.	Measuring Glasses	25 ml., 50 ml., 100ml., 250 ml., 500 ml., (5 pcs)	72
39.	I.V Stand	Tubular MS five legs on castors SS rod and hoops height 160 cm x 230cm power coated.	78
40.	Diathermy machine	Solid state of bipolar and unipolar output 300 watt. With cutting and coagulation circuit color coded, different audible signal, complete with accessories ISO certified.	26
41.	Medicine Distribution Counter	Made of wooden 5 length x 3' width' x height with racks on front side with penal and window complete with storage face duly covered and operator stool	100
42.	Polythene pouch Sealer Machine	Electric operated impulse sealer	26
43.	Mobile O.T. Light	Dome of 500 mm with 1 reflector each with heat conserving. Color correcting filter. 24 v halogen bulb, spring balance system. Sterilizable handle, step down transformer, mounted on heavy still base with 4 castors- intensity 90000 lux diachronic reflector	26
44.	Mechanical weighing machine	Capacity 200 kg x 200 kg superior quality	25
45.	Glucometer	With test range 15-550 mg/dl marked or ISI marked	48
46.	Instrument Tray	With cover 12 x 8 SS to meet IS 3993 with latest Amendment.	74
47.	IR Lamp	Floor model with both or 150 W fitted in metal casing with automatic cut-off timer on 15 minutes	78

		complete with adjustable arm mounted on base with ball bearing casters ISO certified	
48.	Sarvang Vashap Sanvedan Yantra with Trolley Laying Type (Full Body Steam Bath as per specifications)	Fully body steam bath made of water resistance, plywood and hardwood with three windows on each side. Steam is generated electrically with 3 KW heater and boiler each fitted with safety devices. The steam passes in the box from both sides through copper pipes temperature recording by digital thermometer base of wooden frame duly painted chamber size 72x37x28" with generator frame and legs should be of Indian teak wood with fine natural finish. Wood where patient lies should be imported hardwood, complete with steam generator ISO certified.	52
49.	Vasti Yantra	Made or bronze metal and surgical plastic disposal kit with removable tips and bags. SS syringes with adopter head	52
50.	Shiro Vasati Cap	Made of leather, adjustable with vinyl lining	52
51.	Panchkarma Accessories	(16 products) like Uruli, special kindi, ehannikinam, neela vilakku etc.	52
52.	Cervical Cum Lumbar Traction level	Wall mounting electronic cervical traction unit with solid state circuitry, silent motor pulls from 5 to 45 kg treatment time electronic controlled digitally displayed hold time and rest time adjustable in four steps. Complete with traction table. The Lumber section rolls freely on rollers. Cervical traction angle controlled by vertical adjustment complete with storage shelf and flexion stool and accessories ISO certified	26
53.	Patient Waiting Chair	Seat & back made of perforated 0.8 mm thick MS sheet and 19mmx 1.2mm Ms pipe frame and base frame made of 1.6 mm thick SQ pipe size 65x25 mm with arms	80
54.	Room Heater Covered	Electric with two tubes 1000 W ISI marked	54
55.	Table Lamp	Superior	52
56.	Refrigerator	180 litre double door frost free with five bottles and two trays on stand.	52
57.	Mixer Grinder	ISI Marked	52
58.	Instrument Cabinet	3 sides covered with MS sheet of 0.8 mm thick overall size 750 height x 450 width x 300 depth with 2 Nos. MS shelves of 1.0 mm thick, coated with lock and key	26
59.	Oxygen Regulator	With built in BPC flow meter all metal construction with two meters temper proof. Safety blow off large control knob with humidifier bottle.	52
60.	Gas Stove One Burner	Steel body ISI marked with tube to meet IS 4216 with latest Amendment	52
61.	Babcock's Tissue Forceps	6" SS made of 4 series AISI 110 and 420 steel ISO certified and CE marked with CE certificate	26
62.	Kettle Steel	Non electric double walled capacity 10 ltrs. With tap	26
63.	Pindichal Yantra	Variable height dharaathy, suitable for abhanga, shirodhara and nasyam etc. The top is electrically adjustable in height with imported jack for site-to-stand treatment and easy access and transfer of patients from wheel chairs. The Top is mounted on metal frame -work with light blue over baked finish. <ul style="list-style-type: none"> <li>• Height Adjustment: Elctrically, with hand switch. From 25 cm to 95 cm</li> <li>• Dhara System sarvang dhara frame is</li> </ul>	26

		<p>made of stainless steel tube with holes for oil flow on the body.</p> <ul style="list-style-type: none"> <li>• Sirodhara system, made of SS tube is adjustable in height and swings, horizontally on the forehead automatically.</li> <li>• Snehan Yantra is fitted with three low voltage D.C. Motors for different pumps &amp; systems. Oil filtration and oil collecting chamber with Thermostatic temperature control arrangements of the oil.</li> <li>• The oil is automatically lifted and drops on the fore head or on full body. Flow of the oil may be controlled digitally. An electrical Timer stops the treatment at pre-fixed time. A heater keeps the oil soothing hot for the treatment at the pre-fixed temperature. The yantra is elegantly finished, ISO certified.</li> </ul>	
64.	Measuring Jug	Capacity 2 Liter plastic	52
65.	Measuring Bucket	Capacity 10 liter plastic	52
66.	Arshvashp Sanvedan Yantra	Fitted on chair with cushion back electric control with energy regulator and steam generator	52
67.	Weighing Machine Baby	Capacity 10 kg with tray	23
68.	Doctor's Head Light	With adjustable focus with transformer complete with bulb	23
69.	Digital Thermometer	3 digit LCD display auto power of buzzer notice auto memory recall or fast reading water resistant fully washable range 35.5- 42.0 °C Corr. 95.9 -107.6 °F ISI Marked	112
70.	Spatula	S.S. ISO certified	46
71.	Dressing Forceps	ISI.	46
72.	B.P. Instrument with Stand	Stand model with adjustable height heavy base with castors with spring fitted inside the pipe of avoid jerk ISI marked	23
73.	Ice Bag	To meet ISO 386, with latest Amendment	46
74.	Auto Clave vertical	Vertical Pressure type SS seamless electrically Operated, sterilizer 350 x 350 mm to meet IS : 8162 with latest Amendment ISI marked	23
75.	B.P. Instrument	ISI Marked Digital	100
76.	Chester Forceps	SS 12" made of 4 series AISI 110 & AISI 120 steel CE marked with certificate Din Standard : ISO Certified	52
77.	Drinking Water Cooler	Self contained drinking water cooler with refrigerant R22 cooling capacity Ltrs. Hr 80 type storage capacity Ltrs 120 rate of max energy consumption watts : 775	26

**SCHEDULE OF REQUIREMENT & TECHNICAL SPECIFICATIONS OF MACHINERY**

**POICH-PACKING – COLLAR TYPE MACHINE WITH AUGER FILLER**

SPECIFICATIONS

Packing Material	Heat sealable laminated film.
Roll width	Maximum 425 M.M. Minumum 120 M.M.
Pouch type	Central swal pouch
Pouch dimension	Width 50-250 M.M. Height 65-400 M.M.
Power Consumption	4 K watt.
Compressed air required	6 CFM@6 bar.
Production rate	60 shots per minute (various with the nature or product & filling range.
Weight	500 kg
Machine Dimension	Length 1050 M.M. Width- 990 M.M. Height-1360 M.M.

## MICRO-PULVERISER (SCREEN LESS)

### SPECIFICATIONS

Classification is done in whizer cone by adjusting clearance between blade tip and inner surface or cone.

- 1- The feeding is done through the rotary feeder for uniform feeding.
- 2- The complete body is constructed quite air tight to prevent air leak. Main shaft supported by heavy duty bearing for trouble free balanced and cool working.
- 3- Alloy steel or gorged steel hammers are hinged with main shaft with fly back system, tq prevent the breaking of hammer or damaging of finer in case if any foreign material, hard to grind comes across it.
- 4- The whole grinding chamber contains replaceable finer, so that the main body may not be subjected to wear and tear.
- 5- The ground material is sieved to the size by whizzes classifier, and transferred to the cyclone collector pneumatically. The classifier may be adjusted according to the mesh size requirement of material.
- 6- Cyclone mounted on M.S. structure separates air from the ground material and collects material in do bags.
- 7- Fabric bag type dust collector may also be provided to separate fine part ideas from the air.

### PULVERISER-TECHNICAL SPECIFICATIONS

- |                        |              |
|------------------------|--------------|
| 1- Capacity            | 400 Kg/hours |
| 2- Power required      | 25 HP        |
| 3- Speed in            | 2000 RPM     |
| 4- Dia of mill chamber | 24"          |
| 5- No or Hammer        | 8            |

## **DIRECTOR OF AYURVEDA FOR RAJSTHAN, AJMER**

### **EDGE – RUNNER**

#### **SPECIFICATIONS**

- 1- Machine in granite (stainless steel SS)
- 2- Machine 4 ‘ feet size
- 3- No maintenance

## DIRECTOR OF AYURVEDA FOR RAJSTHAN, AJMER

### SPECIFICATIONS

- 01- housing material: SUS 304
- 02- Product conveyor: Plastic steel Top chain
- 03- Filling Tube: ceramic without contamination to product, meet GMP requirement
- 04- Main Motor: TECO brand, 1 HP , AC 1 HP frequency inverter
- 05- Filling Nozzle material: SUS 304
- 06- Automatic Bottle sealing (twin head) 1 set
- 07- Conveyor with gear reducer ¼ HP -40
- 08- Capping Motor: Adjustable speed reduces motor 60w
- 09- Precision index
- 10- Star wheel: plastic steel made
- 11- Mechanical Driving designed
- 12- Automatic inner plug: 2 set or inner plug vibrator, 2 set of inner plug horizon conveyor and 2 set of inner plug guide.
- 13- Automatic out capping 1 set or cap vibrator, cap guide 1 set.
- 14- Automatic bottle-feeding: Bottle feeding vibrator 1 set, bottle feeding guide 1 set. (only of plastic, its maximum diameter 26 mm, bottle height 62mm.)
- 15- Electric controlled by PLC.
- 16- Power source: 220 V 1ø 50/60 Hz.

**Remark:** Bottle, inner plug and out cap should fit on machine and on any cracks.

## HORIZONTAL - MOVABLE-HANDLE

1. ट्रौली प्लेटफार्म लं० 5' फीट (लम्बाई)
2. ट्रौली प्लेटफार्म चौ० 4' फीट (चौड़ाई)
3. ट्रौली व्हील बेस 1' फीट 4" इन्च
4. Wheel size solid tyre 12" x 2" इन्च
5. लेग गार्ड ऊँचाई 1' फीट
6. प्लेटफार्म बेस चद्दर लोहे की 16 गेज की
7. Frame - Channel 3" x 1½ इन्च
8. कम से कम 500 कि० क्षमता वजन ले जाने में सुविधाजनक व मजबूत
9. लेग गार्ड प्लेटफार्म के दोनों ओर
10. चार पहिये solid tyre वाले

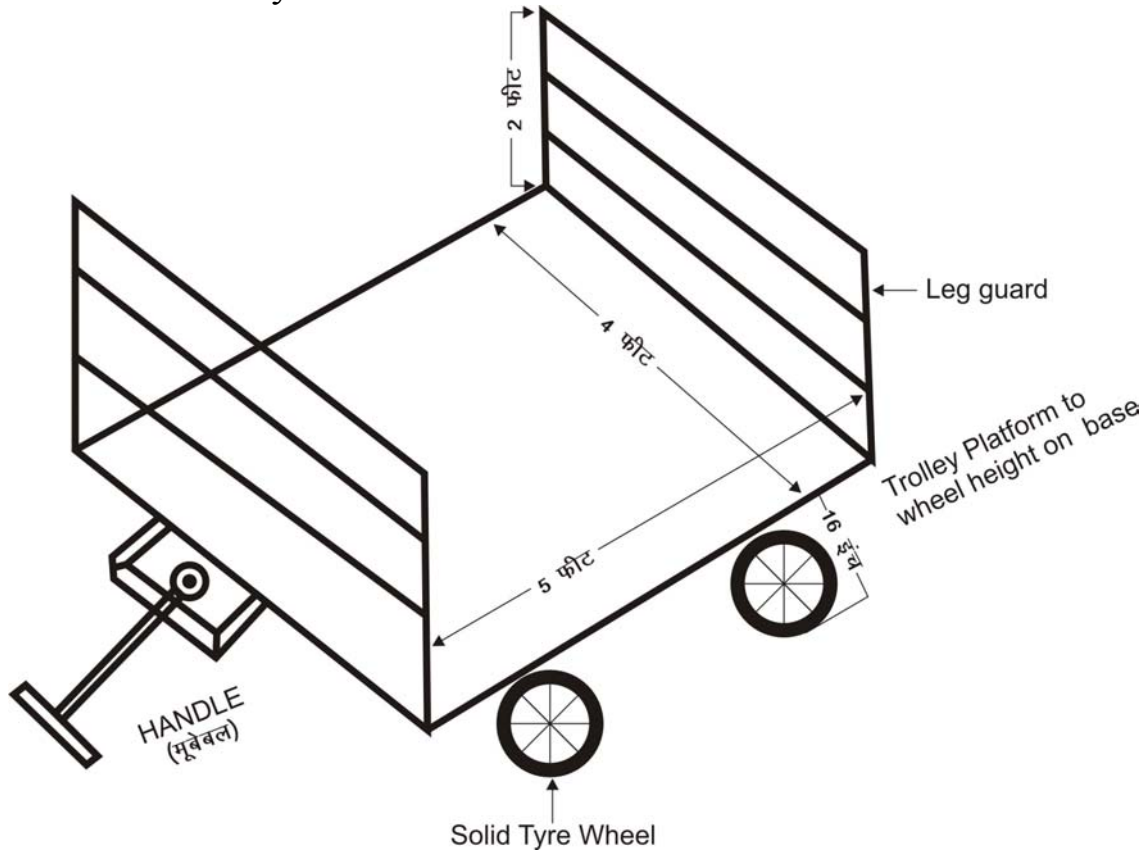

**Delivery:** The Goods are to be delivered with in 8 weeks of signing of the Contract Agreement. In case of Imported Origin Goods, the delivery to be completed with 8 weeks of establishment of L/C.

The **Medical Equipments** to be supplied to **6 Divisional Head Quarters** of Directorate of Ayurveda, Govt. of Rajasthan.

Division wise distribution will be provided along with Notification of Award.

The **Machinery** to be distributed to **4 Pharmacies** of Directorate of Ayurveda, Govt. of Rajasthan.